

ABSTRACT

Vehicle suspension systems have been extensively explored in the past decades, contributing to ride comfort, handling and safety improvements. The new generation of power train and propulsion systems, as a new trend in modern vehicles, poses significant challenges to suspension system design. The development of new-generation suspension systems necessitates advanced suspension components, such as springs and dampers. In the present paper the importance of shock absorber in automobile design and various vibration theories are studied. In this 3D model of the suspension is to be designed using Pro-Engineer Wildfire Version 5 and static analysis of the shock absorber is to be carried out using FEA package. Various structural parameters are to be found by applying a force on suspension and analyzed and then verified for structural stability. Finally an active suspension is designed by making modifications and the method to improve the handling of the vehicle is discussed.

KEYWORDS: Suspension system, dampers, propulsion system, shock absorber.

INTRODUCTION

Passive dampers were used in the early days which offered very poor performance and handling. Semi active dampers were developed in 1960-80's which performed better than the passive systems. The current generation dampers are Active dampers which perform better than the Semi active dampers. Chinny Yue et al [1] developed Control laws for active suspensions in automotive vehicles using the Linear Quadratic Regulator(LQR) and the Linear Quadratic Gaussian (LQG). Bart L. J. Gysen et al [2] developed Active Electromagnetic Suspension System for Improved Vehicle Dynamics that provides both additional stability and maneuverability by performing active roll and pitch control during cornering and braking, as well as eliminating road irregularities. Ian Fialho and Gary J. Balas [3], developed a novel approach to the design of road adaptive active suspensions via a combination of linear parameter-varying control and nonlinear back stepping techniques. Zhang Zhu et al [4], studied about Application of Linear Switched Reluctance Motor for Active Suspension System in Electric Vehicle. Jui Chun Chang [5], studied analysis of series and parallel type active suspension systems using fuzzy logic controllers. Wen - Miin Hwang and Jau Min-Shih [6], studied optimal synthesis of suspension mechanism with variable leverage ratio for a motor cycle. Rahul Uttamrao Patil and Dr. S. S. Gawade [7], studied design and static magnetic analysis of electromagnetic regenerative shock absorber. They presented the design and FEA of an electromagnetic energy regenerative shock absorber which can recover the vibration energy wasted in vehicle suspension system. They studied three methods to recover this waste energy and compared to get best alternative i.e. electromagnetic system. Design process of electromagnetic energy regenerative shock absorber is explained with consideration to space limitations. Mohan D. Rao [8], controlled the noise and vibration in vehicles and commercial airplanes using viscoelastic materials. They hoped the material presented by them may be useful for instruction and further research in developing new and innovative applications in other industries. A. Alleyne et al [9], developed nonlinear sliding control law which can be applied to an electro-hydraulic suspension system. To reduce the error in the model they introduced a standard parameter adaptation scheme, based on Lyapunov analysis. They presented a modified adaptation scheme, which enabled the identification of parameters whose values change with regions of the state space. Performance of the active system, with and without the adaptation, is analyzed by them. From simulation and experimental results they showed that the active system is better than a passive system in terms of improving the ride quality of the vehicle. C. Kim et al [10], investigated the control of an active suspension system using a quarter car model. To ensure robustness for a wide range of operating conditions they designed a sliding mode controller and compared with an existing nonlinear adaptive control

scheme. They also investigated the robustness of the scheme through computer simulation, and showed the efficiency of the scheme in both time and frequency domains. From results they showed that the advantages of the sliding mode control scheme in a quarter car system with realistic non-linearities.

DESIGN OF ACTIVE HYDRAULIC SUSPENSION DAMPER

In this work an active hydraulic damper for an automobile is designed. First a suitable spring for the damper is designed and then the suitable valve, the working piston, orifices on the piston and the piston rod are designed based on the pitch, yaw, and roll motions of the automobile. Then appropriate hydraulic pump is selected for hydraulic actuation. The pump is connected to the dampers using hydraulic hoses. The active hydraulic suspension damper system is shown in Fig. 1. The individual parts designed are assembled and then installed in the automobile.

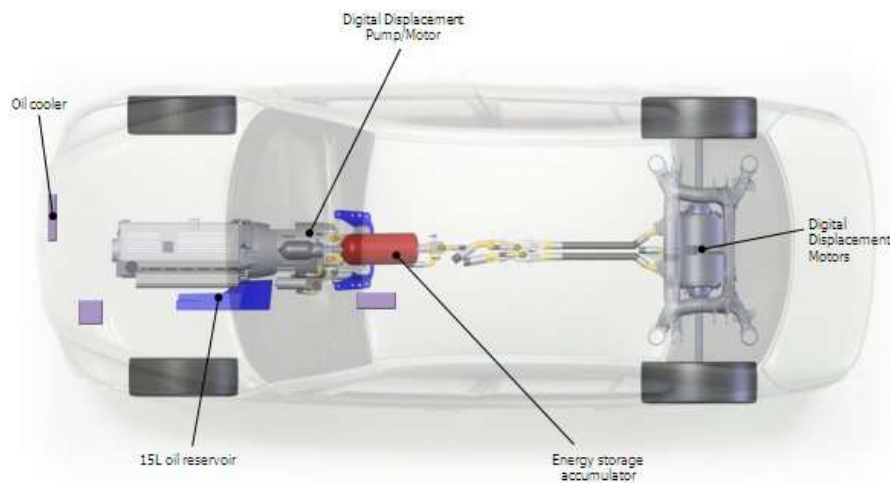

Fig. 1: Active hydraulic suspension damper system

SPRING DESIGN

Springs are widely used in engineering to exert a force. In many critical applications, vehicle suspension springs and engine valve springs, they are subjected to rapid changes in length and their mass must be kept as low as possible to minimize undesirable dynamic effects. ‘Music wire’, AISI 1085 steel is used in diameters up to 3 mm for the highest quality springs. For diameters up to 12 mm AISI 1065 may be used in the hardened and tempered condition or cold drawn. For larger wire diameter, or for highly stressed applications, low alloy steels containing chrome - vanadium, chrome – silicon and silicon – manganese, hot rolled, hardened and tempered (to 50 to 53 Rc hardness, equivalent to about 1600 to 1700 MPa UTS) are used. For the present shock absorber design Chrome Vanadium alloy steel is used because of its desired properties and higher working temperatures. The equations used in the spring design are

- The spring stiffness $(k) = (Gd^4)/8D^3*n$ (1)

- Mean diameter $D = D[\text{outer}] - d$ (2)

- pitch = L_{free} / n , where n is the number of active coils (3)

- $L_{\text{solid}} = (n+2)*d$ (4)

- $L_{\text{wire}} = \pi*D*((n/\cos\alpha)+2)$, where $\alpha = \tan^{-1}(\text{pitch}/\pi*D)$ (5)

- The maximum force that the spring can take
 $F_{\text{max}} = k (L_{\text{free}} - L_{\text{solid}})$ (6)

- Spring resonance
 $\dot{\eta} = (d/9*d^2*[n+2]) *(\text{sqrt}[G/\rho])$ (7)

The factor of safety is usually considered between 1.3 – 2.0

Considering the curvature effect the maximum shear stress in the spring is,

$$\tau_{\text{max}} = (8*W^*D*F_{\text{max}}) / \pi*D^3$$
 (8)

where $W^$ is the Wahl correction factor, which takes care of both curvature effect and shear stress correction factor

$$W^ = \{(4C-1)/(4C-4)\} + (0.615/C)$$
 (9)

By using the equations for design above an appropriate spring is found by trial methods. The Table 1 shows the properties of different springs.

TABLE 1: SPRING ANALYSIS [4]

Property	Spring-1	Spring-2	Spring-3	Spring-4	Spring-5	Spring-6
Diameter (d) of Spring Wire (mm)	11	13	14	14	14	14
Outer diameter (D) of spring(mm)	120	120	125	120	125	120
Free length (L_{free}) of Spring (mm)	350	350	400	350	400	400
Number of active coils(n_a)	20	15	15	12	10	10
Spring constant K (N/m)	5710	1.57×10^4	1.89×10^4	2.67×10^4	2.84	3.26
Maximum load (F_{max}) Possible (N)	617	2030	3070	4120	6590	7560
Maximum shear stress (Mpa)	148	296	375	464	805	889
Maximum displacement (L_{def}) possible (mm)	108	129	162	154	232	232
Length of wire to make the spring (mm)	7540	5730	5940	4860	4210	4020
Solid height (mm)	242	221	238	196	168	168
Distance between coils in free spring (mm)	17.5	23.3	26.7	29.2	40	40
Rise angle of coils	2.93^0	3.97^0	4.37^0	5.01^0	6.54^0	6.85^0
Resonant frequency (Hz)	15.9	25.7	25.7	34.4	37.4	41
Mass of Spring (kg)	5.63	5.97	7.18	5.65	5.08	4.86

As the properties of spring 6 are suitable for the present design, it is selected.
 The total force along x is

$$\sum F_X = F_{DC} + P_{At}A_R + P_{EC}A_{PA} - P_{CC}A_P + F_{FR} + F_{FP} = m a_X \approx 0 \quad \dots (10)$$

The combined mass of the piston and rod is about 400 g for an average car damper. For sinusoidal motion at amplitude X_0 and frequency f , giving radian frequency $\omega = 2\pi f$, the peak acceleration is $X_0\omega^2$ and peak speed $X_0\omega$. Even at an acceleration of 100 m/s^2 , the acceleration force is 40 N and negligible compared with the damping force. The piston rod can easily sustain the loads of such magnitude. Also the acceleration force is out of phase with the peak speed, and hence for sinusoidal motion has little or no effect on the peak force.

ACTIVE HYDRAULIC SUSPENSION DAMPER DESIGN

Pitch, Yaw, Roll motions of an automobile:

- Rotation around the front-to-back axis is called roll.
- Rotation around the side-to-side axis is called pitch.
- Rotation around the vertical axis is called yaw.

For a better handling the pitch, roll and yaw motions should be minimized. The free body diagram for pitch analysis is shown in Fig. 2. *Pitch analysis: (Braking and acceleration)*

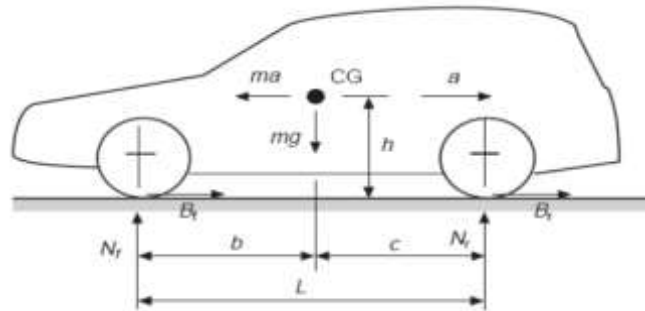

Fig. 2: Pitch analysis free body diagram Moment about the rear tyre gives
 $-N_f L - mah - mgc = 0$
 $-N_f = mah/L + mgc/L$
 $-N_f = mgb/L - mah/L$ (11)

An average sedan is taken as an example and the forces acting on the suspension dampers are analyzed. The specifications of the sedan are: Length = 4503mm, Width = 1752mm, Height = 1435mm, Ground clearance = 170mm, Wheel base = 2670mm, Mass(m) = 1180kg, Track = 1525mm.

Considering the weight distribution of a loaded sedan, the centre of gravity is found to be

$$CG = (1335, 762.5, 470.5)$$

Considering the free body diagram of the car as shown in the above figure, the acceleration of the car is taken as $a = 6m/s^2$. Substituting the values and solving for N_f from the moment Equ. (11):

$$m = 1180 \text{ Kg}, g = 9.8, b = 1.335, c = 3.168m$$

We get the value of force acting on the suspension (N_f) = 9800N.

By controlling the pressure of the fluid pumped into the damper, damping force can be regulated, hence providing a comfortable ride. For pitch control during braking the force is applied in upward direction to the front wheels by the active suspension. To the rear wheels a down force $F = m \cdot a$ may be applied to maintain tyre-road contact. During acceleration the analysis is similar, but the loading takes place on the rear wheels.

ROLL ANALYSIS:

As soon as a car starts to go around a corner, its vertical tyre loadings will change. Because of the cornering force, weight will be transferred from inside of the tyres to outside. This change in loading is dependent on the cornering force (g's), car track width T, height of the center of gravity(H) and overall weight of the car. The full car model with suspension units is shown in Fig. 3.

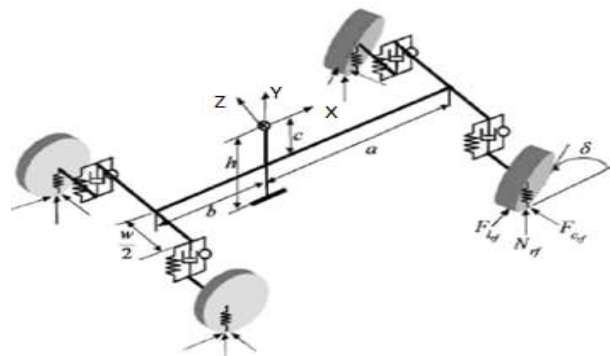

Fig. 3: Full car model with suspension units

$$\text{Lateral weight transfer} = \frac{\{(W)*(g's)*H\}}{(Gravity*T)} \dots\dots (12)$$

Substituting the values of the car dimensions, weight and the cornering speed of the car is 80kmph.

The lateral weight transfer = 122.77kg (in outward direction). Which means an extra force of 615N is acting on each outward suspension. This extra force can be neutralized by applying an opposing force in upward direction by activating the suspension system of the outer wheels. Similar force application in downward direction to the inner wheel suspensions helps in sticking the tyres to the road. The analysis is similar in both left and right directions. Hence the roll over is minimized. For the modification of the hydraulic suspension system, a 25-30 bar hydraulic pump is required. *Hence for the current design a 30 bar hydraulic pump and an appropriate hydraulic accumulator are selected and installed.*

ANALYSIS OF THE SUSPENSION DAMPER

For the analysis first the damper is modeled in Pro-E Wildfire Version 5, the modeled individual parts are assembled and then the assembly is converted to IGES format. The IGES file is then imported into ANSYS 14.0 workbench and analyzed. The 3D model of total suspension system is shown in Fig. 4. The constrained model of total suspension system is shown in Fig. 5. The total deformation results of a suspension system are shown in Fig. 6. The equivalent elastic strain results are given away in Fig. 7. The equivalent stress results are shown in Fig. 8. The maximum deflection that is obtained from the suspension system is 0.12m. The maximum and minimum equivalent elastic strain that are obtained from Fig. 7 are 0.01m and $4.665*10^{-7}$ m. The maximum and minimum equivalent stress for the constrained suspension system is $1.8029*10^9$ Pa and 18364 Pa.

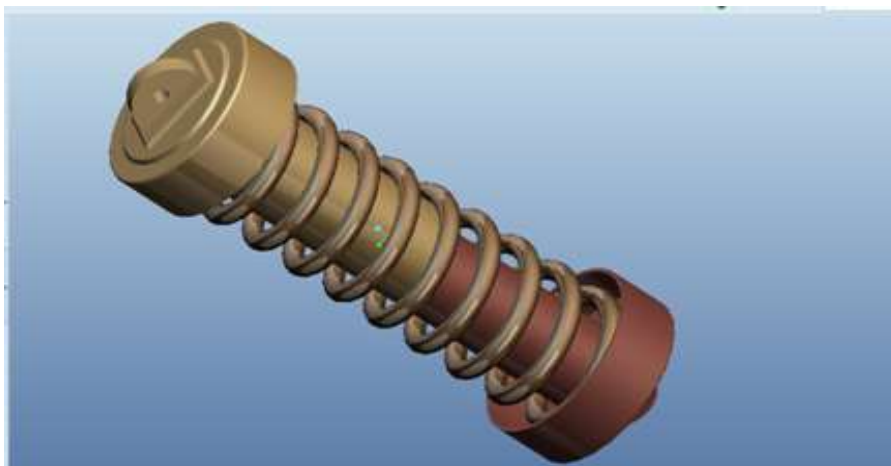

Fig. 4: 3D model of total assembled suspension

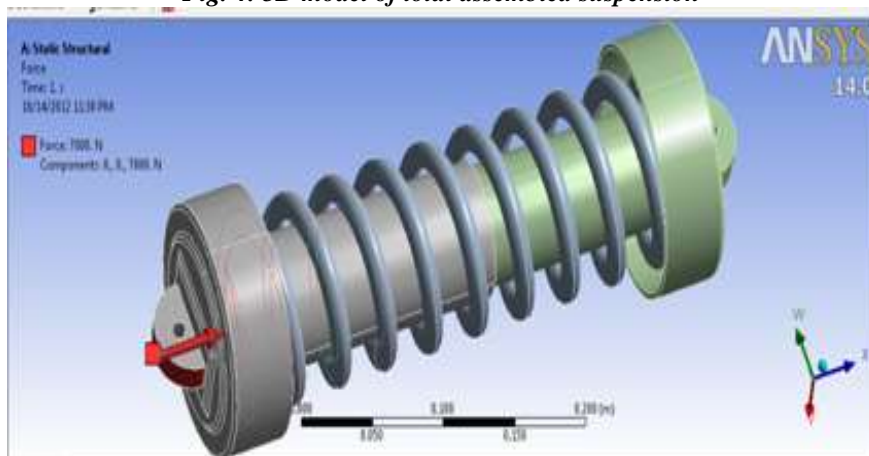

Fig. 5: Application of constraints and forces

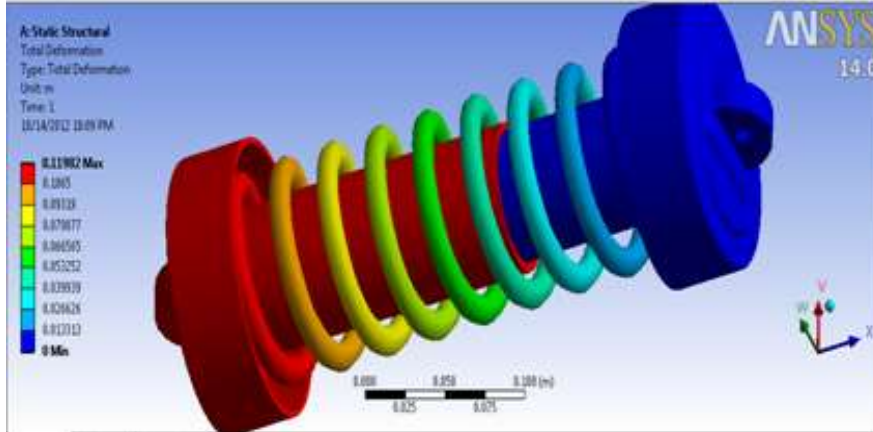

Fig. 6: Total deformation results

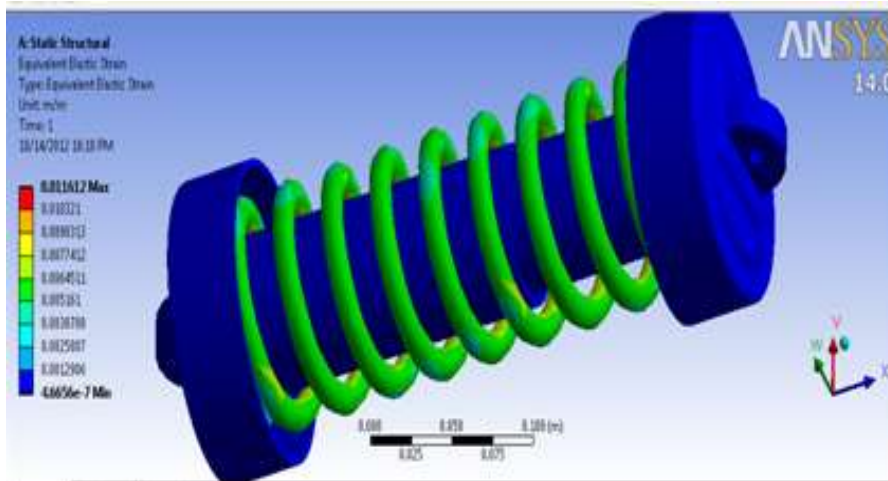

Fig. 7: Equivalent elastic strain results

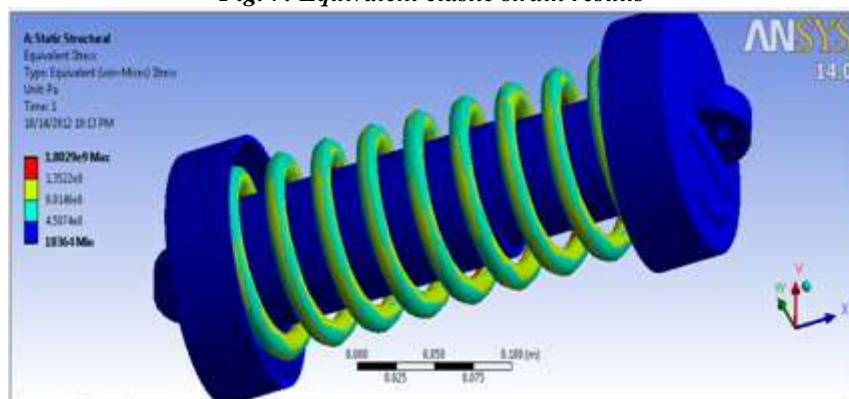

Fig. 8: Equivalent stress results

CONCLUSIONS

For a typical passenger car an active hydraulic suspension damper system is designed, modeled in Pro-E and analyzed in ANSYS Workbench. The designed damper is found to be structurally safe and modifications are done to it to provide effective actuation forces. As a result it offers better handling than conventional systems. The deflection in the analysis is 0.12m which is less than the maximum deflection 0.23m. The stresses are also less than the maximum stresses of the chrome vanadium. Hence the results are verified and the suspension is found to be structurally safe.

REFERENCES

- [1] Chinny Yue, T. Butsuen, J. K. Hedrick, "Control laws for active suspensions in automotive vehicles", American Control Conference, 1988, PP 112-119.
- [2] Bart L. J. Gysen, Johannes J. H. Paulides, Jeroen L. G. Janssen and Elena A. Lomonova, "Fellow Active Electromagnetic Suspension System for Improved Vehicle Dynamics", IEEE, Vol. 59, Issue 3, 2010, PP 1-8.
- [3] Ian Fialho and Gary J. Balas, "Road Adaptive Active Suspension Design Using Linear Parameter-Varying Gain-Scheduling", IEEE, Vol. 10, Issue 1, 2002, PP 43-53
- [4] Zhang Zhu, Norbert C. Cheung and K.W.E Cheng, "Application of Linear Switched Reluctance Motor for Active Suspension System in Electric Vehicle", The Hong Kong Polytechnic University, Hong Kong, 62, Issue 2, 2013, PP 562 – 572.
- [5] Jui Chun Chang, "Analysis of series and parallel type active suspension systems", Ta Hwa Institute of Technology, Hsinchu, Taiwan.2007, PP 1-10.
- [6] Wen-Miin Hwang and Jau Min-Shih, "Optimal synthesis of suspension mechanism with variable leverage ratio for a motor cycle", Journal of Chinese Society of Mechanical Engineers, Vol. 8, No. 1, 1987, PP 43-50.
- [7] Rahul Uttamrao Patil, Dr. S. S. Gawade, "Design and static magnetic analysis of electromagnetic regenerative shock absorber", International Journal Advanced Engineering Technology, Vol. 3, Issue 2, 2012, PP 54-59.
- [8] Mohan D. Rao, "Recent applications of viscoelastic damping for noise control in automobiles and commercial airplanes", Journal of Sound and Vibration, Vol. 262, Issue 3, 2003, PP 457-474.
- [9] A. Alleyne, J. K. Hedrick, "Nonlinear adaptive control of active suspensions", IEEE Transactions on Control Systems Technology, Vol. 3, Issue 1, 1995, PP 94-101.
- [10] C Kim, P I Ro, "A sliding mode controller for vehicle active suspension systems with non-linearities", Journal of Automobile Engineering, Vol. 212, Issue 2, 1998, PP 79 – 92.